

TECHNICAL INSTRUCTION SHEETS

WORLD ASSOCIATION OF TECHNOLOGY TEACHERS

<https://www.facebook.com/groups/254963448192823/>

www.technologystudent.com © 2017

MARKING OUT AND CUTTING: A PLAIN MORTISE AND TENON

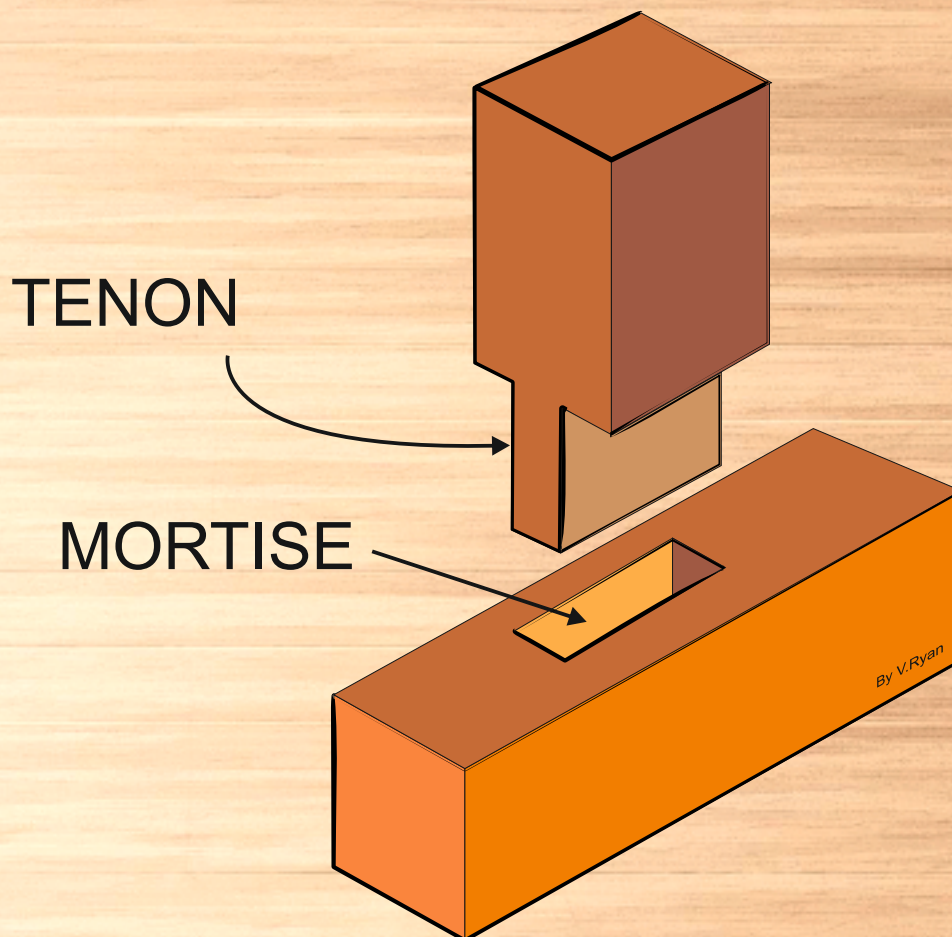

NOT TO BE PLACED ON POWERPOINTS OR ANY
OTHER MEDIA. NOT TO BE EDITED IN ANY WAY.
V.Ryan © 2017

MARKING OUT AND CUTTING THE TENON

The tenon part of a mortise and tenon joint is marked out and cut with the same tools as are used for the mortise part of the joint.

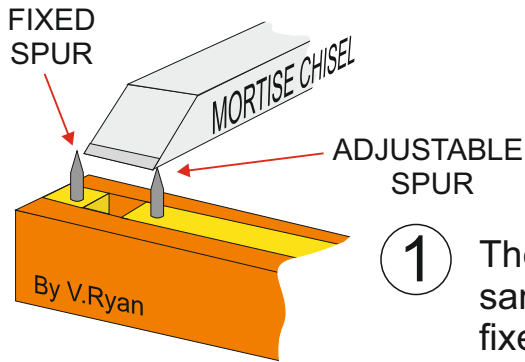
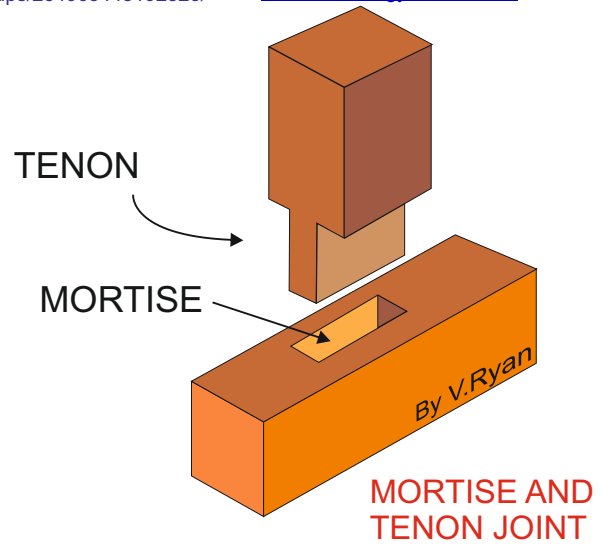

- 1 The mortise chisel is carefully selected. It should be the same width as the mortise to be cut into the wood. The fixed spur and the adjustable spur of the mortise gauge are set to the width of the chisel.

- 2 The width of the tenon is marked all the way round the wood. Normally a marking knife is used to produce a precise line, with the aid of a try square. A pencil can then be used make the line stand out.

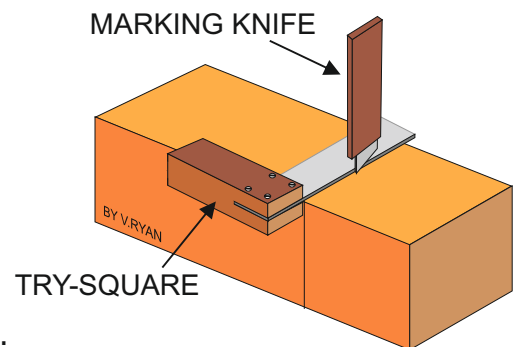

- 3 The mortise gauge is used to mark the size of the tenon. The stock of the marking gauge must be held firmly against the side of the wood as it will have a tendency to follow the grain of the wood rather than a straight line.

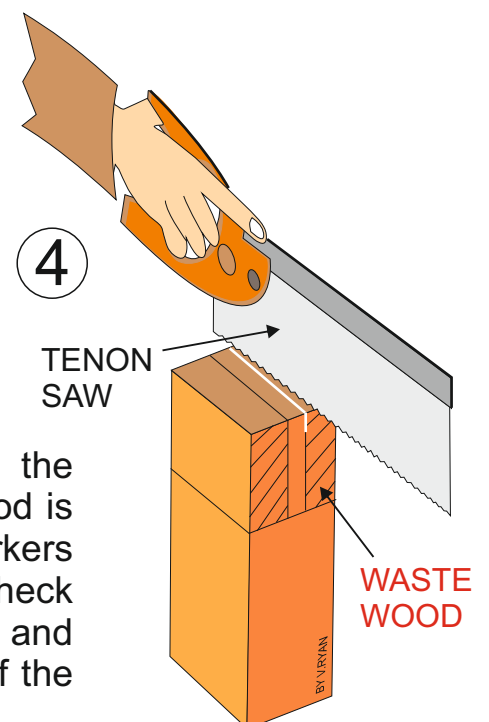

A tenon saw is used saw down the gauged lines of the tenon. The wood is normally held firmly in a woodworkers vice. When sawing, take time to check that the saw is cutting straight down and that it is on the waste wood side of the tenon.

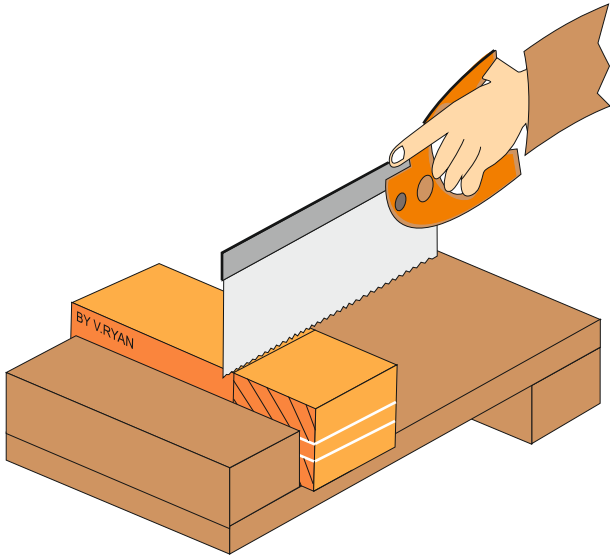

5 The wood is then supported by a bench hook and a tenon saw is used to finally remove the waste wood. This leaves the shoulder of the joint.

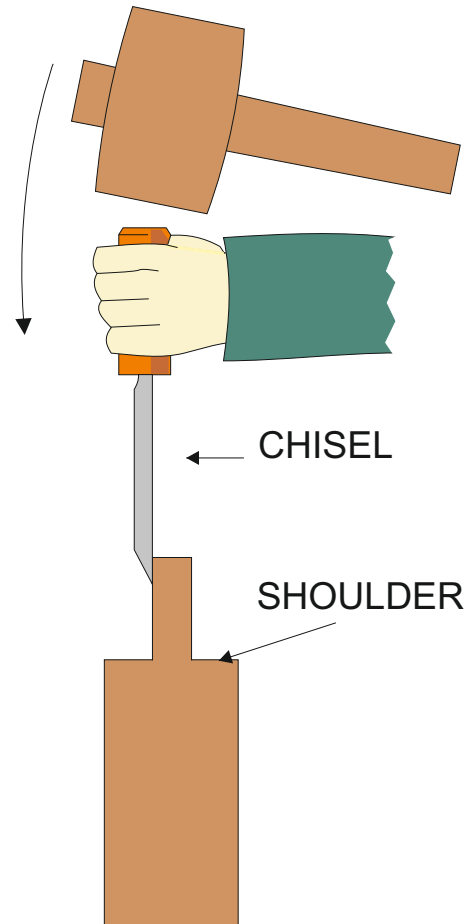

6 A firmer or bevel edged chisel can be used to remove rough edges and to straighten the tenon. The wood must always be held in a woodworking vice as a chisel may slip if the wood moves. If the marking out and cutting have been carried out accurately the mortise and tenon should fit together forming a firm joint.

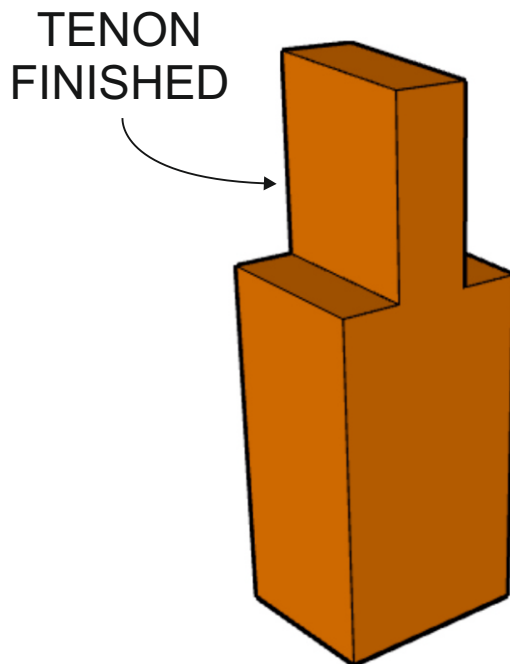

MARKING OUT AND CUTTING THE MORTISE

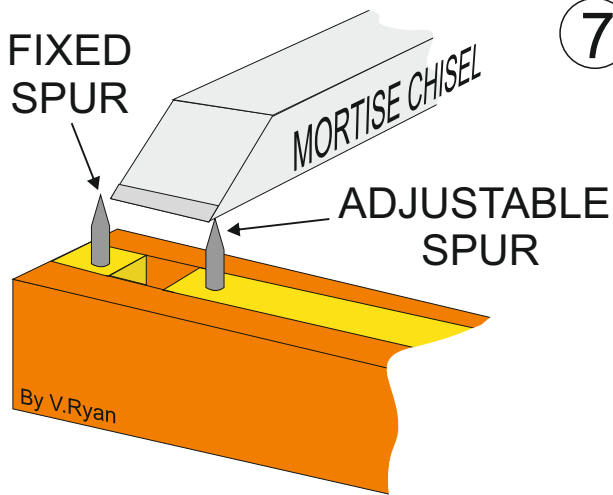

- 7 The distance between the fixed spur and the adjustable spur is set so that it matches the width of the mortise chisel. This done by turning the brass thumb screw. The width of the mortise chisel should match the width of the mortise to be cut in the wood.

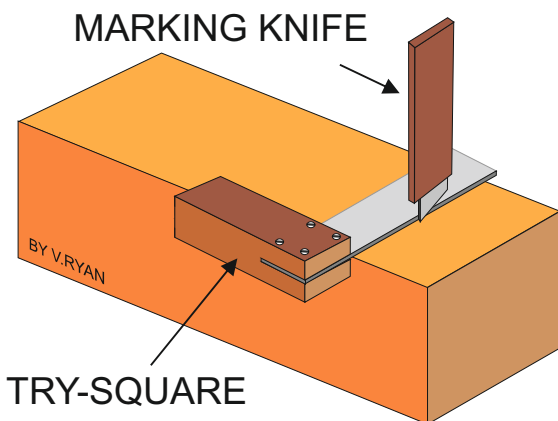

- 8 A try square and a marking knife are used mark the lines at the top and bottom of the mortise.

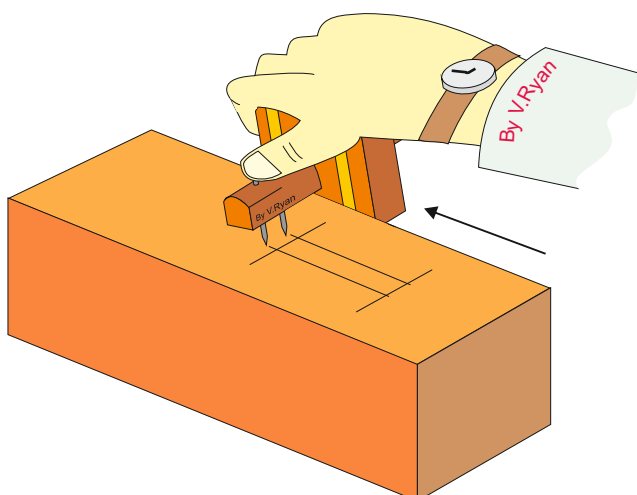

- 9 The stock of the mortise gauge is pressed against the side of the wood. It is then pushed along the wood until the mortise is marked out correctly.

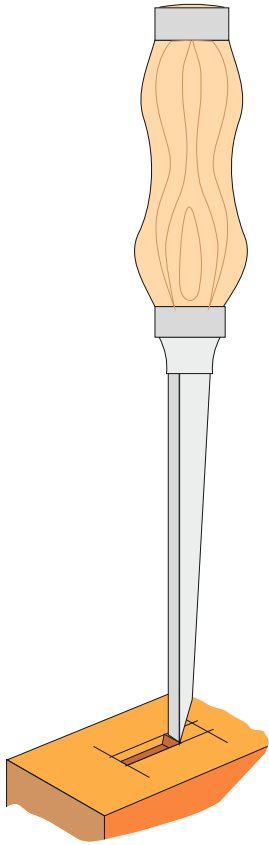

10 The mortise chisel is then used to remove the waste material. A mallet provides the blows to the chisel. With great care, an accurate mortise can be cut.

11 The mortise chisel is then used to break the surface of the waste wood by gently tapping the handle with a mallet.

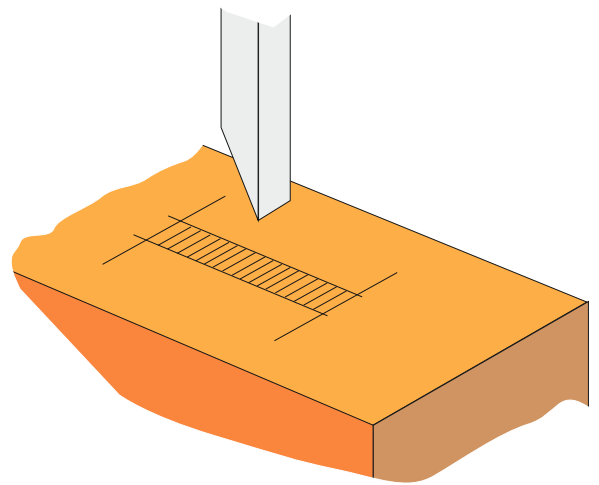

12 The waste wood is then slowly removed, this time, by applying more force to the handle of the chisel with the mallet. The waste is removed until the entire mortise hole has been cut.

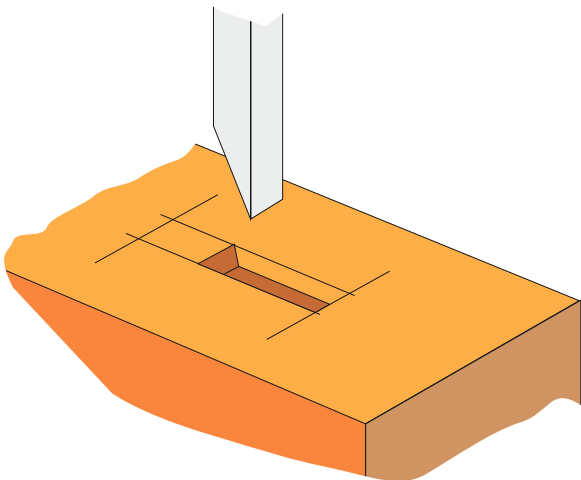

COMPLETED
PLAIN MORTISE AND TENON JOINT

